

## OPENING ROOFS SPECIFICATIONS

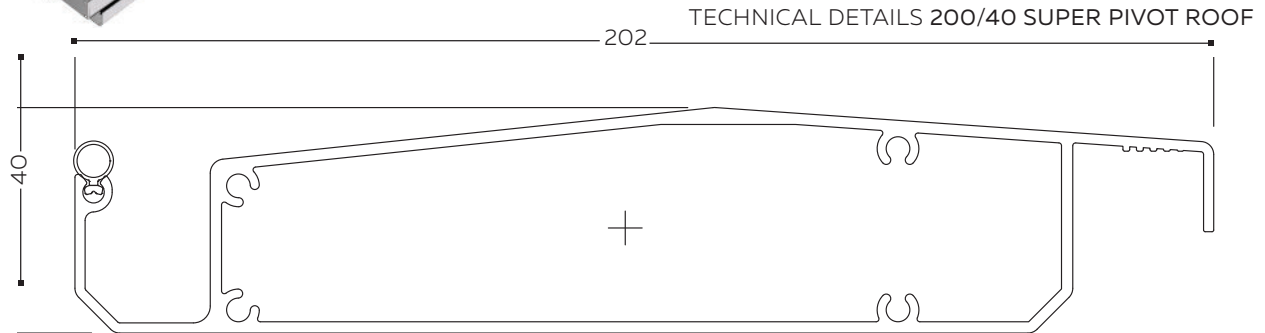

BLADE SPECIFICATIONS			
Blade cover - opening system	188 mm	Weight per linear metre - opening system	2.624 kg/lm
Weight per square metre - opening system	13.93 kg/sqm	Actual blade width	200 mm
Blade centres - opening system	188 mm		

### SPANS AT A GLANCE NB:

Refer Engineering Section. Climate, terrain, shielding, location, type of structure contribute to determine spans.

WIND ZONE	INSIDE	LOW	MEDIUM	HIGH	VERY HIGH	EXTRA HIGH
Factored wind speed at building	Self wt	32 m/s 115 km/hr	37m/s 133 km/hr	44 m/s 158 km/hr	50 m/s 179 km/hr	55 m/s 198 km/hr
Ultimate limit state loads (kPa)		+0.92 & -1.15	+1.23 & -1.53	+1.74 & -2.17	+2.24 & -2.80	+2.71 & -3.39
200/40 Super Pivot Roof	5600	4500	4500	4000	3500	3150

### INSTALLATION OPTIONS



#### CALCULATE OPTIMUM FRAME OPENING SIZES FOR SPIRAL PIVOT

Span: Check engineering span limits

Pivot: Calculation example showing 17 blades

#### STEP 1

16 blades x 188 Crs	3008
1 blade at 200 (blade size)	+ 200
17 blades	= 3208

#### STEP 2

Blade cover	3208
+2/22mm clearance @ ends =	44
Total exact pivot length	= 3252
Extra width 185mm gutter provides cover if clearance increases over 22mm at ends.	
Blade direction either Right Hand up or Left Hand up.	

### CHOOSE DIRECTION OF BLADE PIVOT

